

Notes :

1. INLET is Ø110 mm. Suitable reducers should be used to step down from bigger pipework. Supplied by others. OUTLET is Ø50mm MDPE fitting to suit Ø50mm O/D pumping main.
2. Units invert is adjustable by trimming external riser to required height. Selection of correct invert is key and must be suitable for drainage and ground levels on site.
3. Ext neck kit available for deeper inverts up to a maximum invert of 1500mm.
4. It is important to read and understand installation operation and maintenance guidelines before attempting to install this unit.
5. Vent pipe connections are supplied but vent runs and stacks are supplied by others.
6. The unit will normally need de sludged annually. However this is dependant on use.
7. Tank Weight (Empty) - 305 Kgs

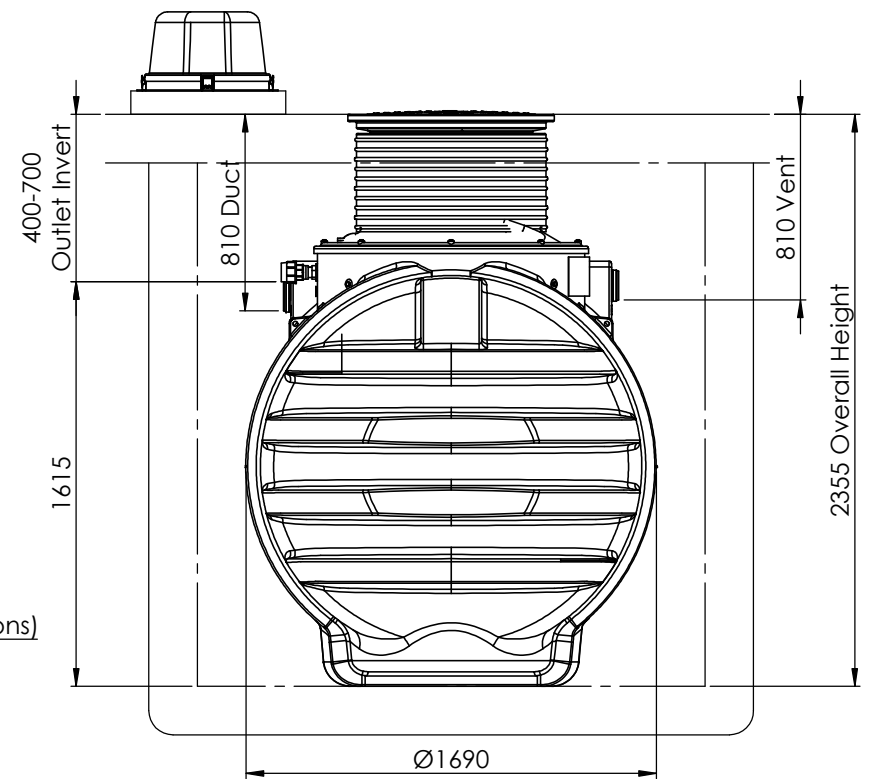

Please check with Kingspan Environmental that this drawing is the latest issue			
Issue	Date	Drawn by	Approved by
01	02/09/15	JMcM	
Description			
Initial Release			

Material : Various
Finish :
Weight : 201.37 Kg Kgs

Tolerance :
Thickness : n/a
Surface Area :

Drawing : DS1274P	Page 1 of 1
BioFicient+ 1 TP Sales Drawing - IPS	

All dimensions in mm	Scale: Not to scale
----------------------	---------------------

Kingspan Environmental reserve the right to alter the details of this drawing without prior notice. This drawing is copyright and may not be reproduced or used without the written permission of Kingspan Environmental.

